



Petrochemical Industry

Inline analytical measuring
technology for:

- Concentration & density
- Phase separation
- Oil and gas quality
- Multi-component mixtures
- Gas scrubber
- Alkylation

Increase quality, save resources: LiquiSonic®.
With high-quality, innovative sensor technology.
Robust, precise, user-friendly.

LiquiSonic®

LiquiSonic® is an inline analytical system for determining the concentration in liquids directly in the production process. The analyzer is also used for phase separation and reaction monitoring. Sensor installation within the product stream means an extremely fast measurement that responds immediately to process changes.



User benefits include:

- optimal plant control through online and real-time information about process states
- maximized process efficiency
- increased product quality
- reduced lab costs
- immediate detection of process changes
- energy and material savings
- instant warning of interruptions in the process water or process liquid
- repeatable measuring results

LiquiSonic's® 'state-of-the-art' digital signal processing technology guarantees highly accurate, fail-safe measuring of absolute sonic velocities and liquid concentrations.

Integrated temperature detection, sophisticated sensor design, and know-how from SensoTech's extensive measurement history in numerous applications promises users a highly reliable, long life system.

Advantages of the measuring method are:

- absolute sonic velocity as a well-defined and retraceable physical quantity
- independent from conductivity, color or optical transparency of the process liquid
- installation directly into pipes, tanks or vessels
- robust, all-metal, gasket-free sensor design with no moving parts
- corrosion-resistant by using special material
- maintenance-free
- use in temperatures up to 200 °C (390 °F)
- accurate, drift-free measurements
- stable measurements even amid gas bubbles
- controller connection capacity reaching up to four sensors
- data transmission via fieldbus (Profibus DP, Modbus), analog outputs, serial interface or Ethernet

Inline process analysis

Contents

Applications	4
Concentration measurement and product quality	4
Quality determination (ethylene oxide)	5
Phase separation	5
Water Cut Analyzer	6
Fuels and water infiltration	6
Gas scrubbers	7
Methyl diethanolamine (MDEA)	9
Benfield synthesis gas scrubber	10
Alkylation (HF, H₂SO₄)	11
LiquiSonic® System	14
LiquiSonic® 20 und 30	14
LiquiSonic® 40	15
Accessories	16
Controller rack mounting	16
Fieldbus	16
Controller stainless steel housing	16
Network integration	17
Quality and Support	18
SensoTech	19



Applications

Concentration measurement and product quality

Explosive, corrosive and partly very hot or toxic – those are the characteristics of typical petrochemical process liquids. Whether offshore, in the refinery or petrochemical factory, suitable measuring systems must be able to handle such media in a robust and sustainably stable manner. Apart from that, correct process control must be ensured under even the harshest environmental conditions, e.g. in explosive areas or salty atmospheres.

The use of the LiquiSonic® measuring technology and its easy integrability into existing systems, allows considerable improvements of system utilization, process safety and product yield with relatively low project costs.

Especially in the petrochemical industry, LiquiSonic® systems have opened up versatile fields of application for more than 30 years:

- Fast detection of transitions between product and carrier phases
- Concentration measurements at different quality and safety-relevant process points
- Concentration measurement in complex substance mixtures (multi-component analysis) to control process engineering processes
- Inline monitoring of gas scrubber concentrations for quick intervention

Correlation between sonic velocity and concentration of binary liquids

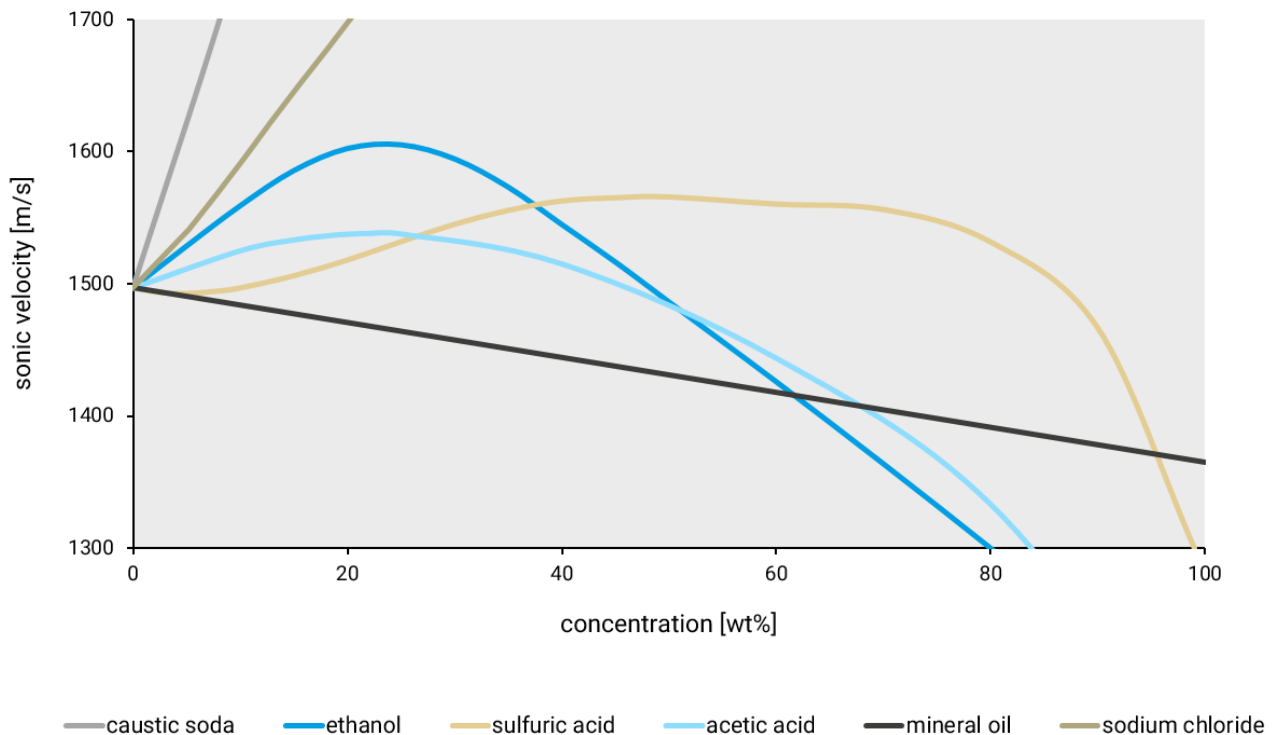

Quality determination

Numerous products of petrochemical processes serve as starting materials for chemistry, pharmacy, plastic production, fertilizer syntheses, etc. This requires continuously monitoring the quality standards of the end product and/or the incoming flow of goods. For example, foreign substances and concentration fluctuations in the ethylene oxide (EO) quality are to be identified in due time.

LiquiSonic® systems are also effective in non-conductive process liquids. SensoTech offers tried and tested sensor solutions for the control of liquid gases and applications in the Ex area. Typical examples include quality control and density measurement for a wide range of products, such as LPG, naphtha, fuel oil, butane, and propane. Faulty batches, faulty dosing and poor quality can be detected in the incoming goods control.

The quality and concentration of different liquified gases can be challenging. Operators need a robust, drift-free measuring device in hazardous areas that logs data and accurately detects fluctuations and range exceedances. LiquiSonic® systems meet these challenges and are easy to operate.

Phase separation

With numerous process engineering interim steps, different product phases must be safely separated from carrier phases. This is done in both continuous procedures and in batch processes.

This is often realized in batch processes by the manual switching of valves as well as visual observation of phase transitions (inspection glasses). This approach is, however, marked by minor reproducibility. Automation can easily be realized by the use of a LiquiSonic® immersion sensor. The change of the sonic velocity shows a typical, significant change in the signal between the individual phases. This enables LiquiSonic® to supply a clear signal for the safe and reproducible separation of the product and carrier phase. The fast sensor response time allows for high separation precision which immediately results in considerable product savings. Repeated phase separation process steps are successfully avoided.

LiquiSonic® systems have been successfully implemented in the detection and separation of:

- Monitoring of multi-substance pipelines
- Fuels / water
- Oil / salt water
- Glycerine / bio diesel
- Gas / liquid phases

Unlike conductivity sensors, LiquiSonic® sensors may also be used in the different separation processes of watery and organic phases. The continuous measurement allows for the setting of almost any separation areas within the transition or sludge phases. The signal development can be directly observed using the controller trend view. There, switching thresholds of the digital controller outputs can be parameterized. For isolated solutions, these outputs can directly switch existing multiport valves or valve clusters.

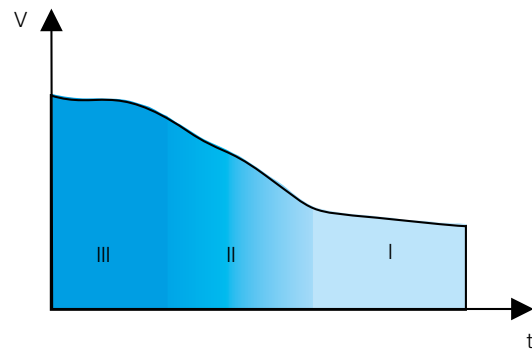
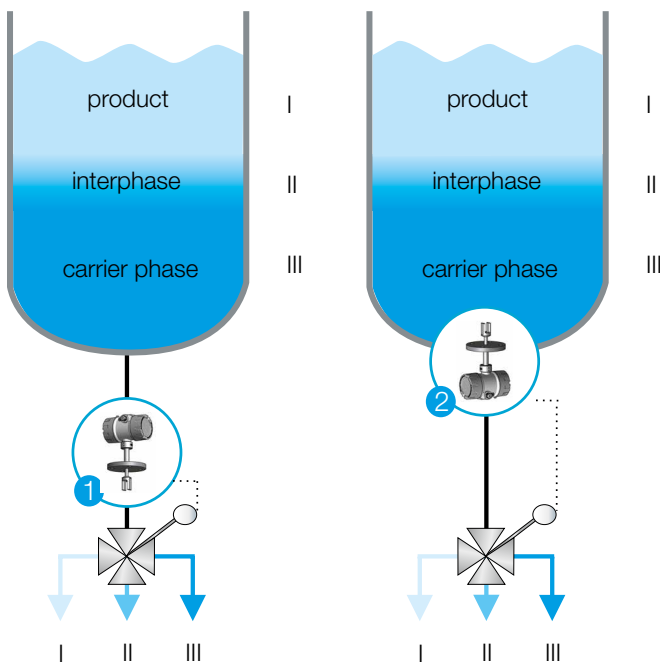

Measuring point	Installation	Measuring task
1 2	drainage	phase identification in the batch process

Phase separation in batch process

Water Cut Analyzer

Due to the difference in the density of oil and salt water, the two phases can be separated. The salt water is pumped out from below the oil. The separation of the salt water from the oil can be monitored by means of LiquiSonic® measuring technology. In this connection, the characteristic sonic velocities of the relevant phases are measured and evaluated at the controller. This allows for phase separation in a matter of seconds.

Despite high flow rates, even short water and oil sections are detected and separated as quickly as possible thanks to an extremely short reaction time (< 1 second). This precise salt water separation results in an increase in the oil yield. Ensuring the necessary quality for the subsequent processing in the refinery.

LiquiSonic® sensors supply clear, temperature compensated concentration values for the different process liquids. In this way, the following tasks can be performed at relevant points of process engineering processes:

- Monitoring and detection of incoming goods
- Quality monitoring for intermediate products
- Control and monitoring (dilution, concentration, product infiltrations)
- Monitoring of the end product quality

Fuels and water infiltration

The determination of the product type and the water content are elementary for the quality assurance of petrochemical products. LiquiSonic® systems are successfully used for the detection and differentiation between heating oil, petrol, diesel, kerosene and other fuels. Additionally, the water content can be precisely determined by inline sonic velocity sensors and transferred to process control systems using different fieldbus options like Profibus DP or Profinet.

Faulty fillings and supplies of lower quality levels are successfully avoided. Water infiltrations in fuel can also be detected inline to ensure system safety.

Phase separation by means of LiquiSonic® sonic velocity measurement

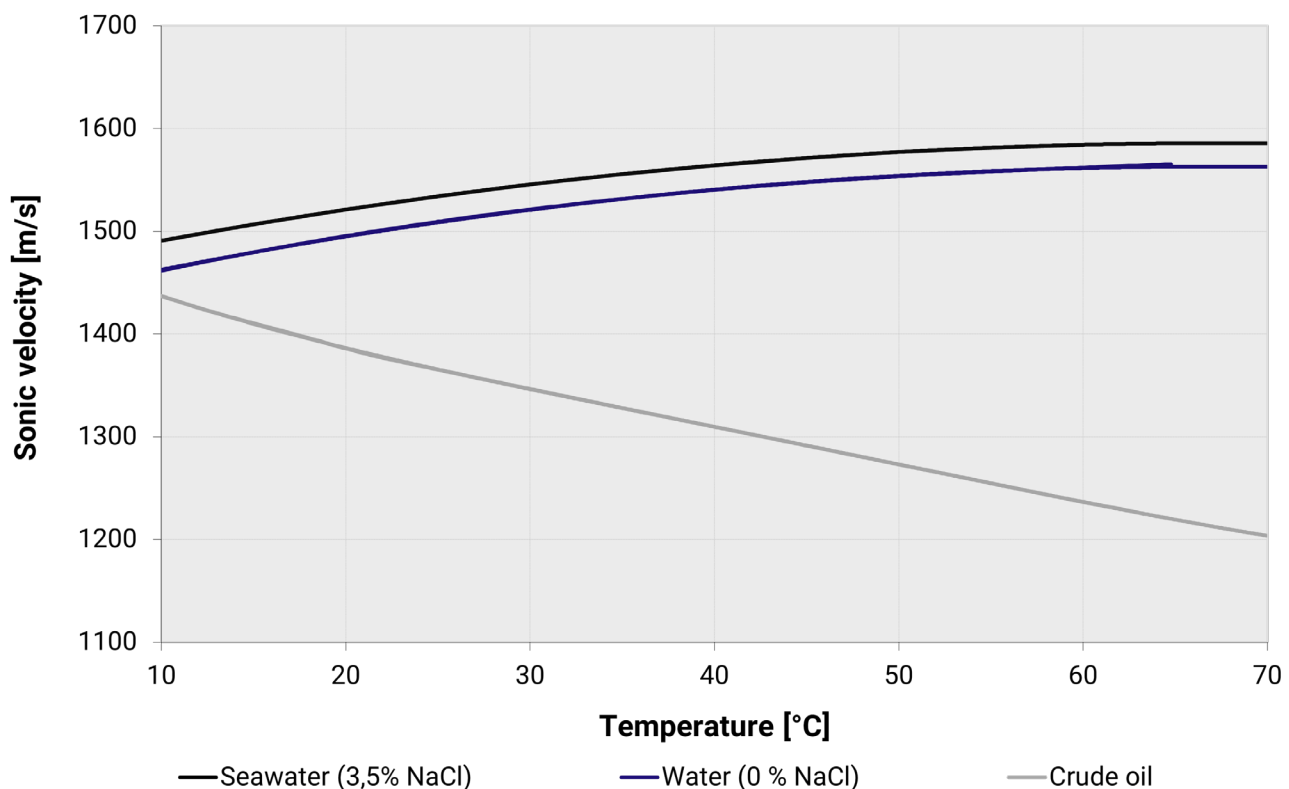

Gas scrubbers

Gas scrubbers are an important part of petrochemical plants. Here, the liquids to be measured mostly comprise of three main components.

Typical examples include:

- MDEA (piperazine) / water
- Caustic soda / sodium chloride and carbonate / water
- Potassium carbonate / potassium hydrogen carbonate / water

In the gas scrubber column, a washing liquid is brought into contact with the gas flow to be cleaned. Whereby certain gaseous, liquid, and solid components, including harmful, toxic, and environmentally damaging substances, are absorbed by the liquid.

Regarding the process analysis in gas scrubbers, there are different measuring points at which LiquiSonic® systems are successfully installed. Their use allows for the separate determination of the scrubbing solution concentration and of the salt, inline and without time delay. Thus, defined dosing of the washing liquid is possible and the liquid concentration can be held in the range of maximum solubility and/or absorption.



Underdosing i.e. insufficient cleaning, is avoided, but also overdosing. Avoiding excessive material use and the related costs and resource consumption.

The robust sensor construction and the selection of special materials such as Hastelloy or PFA sensor coatings ensure long process life of the system.

Using the LiquiSonic® system, the concentrations of individual components in multi-substance mixtures can be determined with the help of an additional physical measurement. Conductivity sensors are typically used for this purpose.

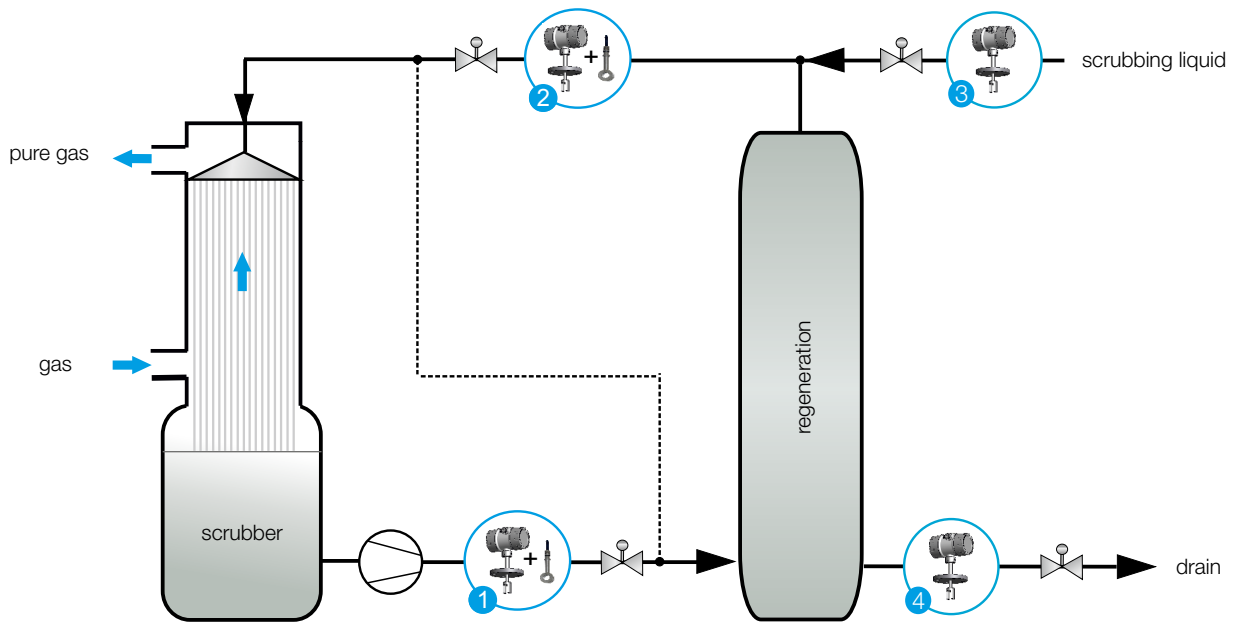

Measuring point	Installation	Measuring task
1 2	pipeline	concentration monitoring of the scrubbing liquid and salt
3	pipeline	concentration monitoring of the fresh scrubbing liquid
4	pipeline	break-in monitoring during the treatment of salts

Inline gas scrubber monitoring

Continuous monitoring of the NaOH and salt concentrations is particularly necessary at gas scrubbers and neutralization columns in order to:

- Minimize the caustic soda use through concentration-controlled operation
- Avoid corrosion caused by non-neutralized, acid process liquid
- Avoid emergencies and financial penalties (emergency vent scrubber) in case of underdosing

As compared to pH value measurement, monitoring of both concentrations opens up extensive process optimization options and almost unlimited runtimes. Cost-intensive calibration and maintenance are no longer required.

Examples of common applications:

- Flue gas scrubbers
- Gas drying
- Phosgene absorbers
- Sulphur dioxide scrubbers
- Benfield scrubbers
- Ammonia systems
- Synthetic gas systems
- Natural gas systems
- Chlorine gas scrubbers
- Emergency vent scrubbers
- Phosgene gas scrubbers
- Amine Gas Scrubbers

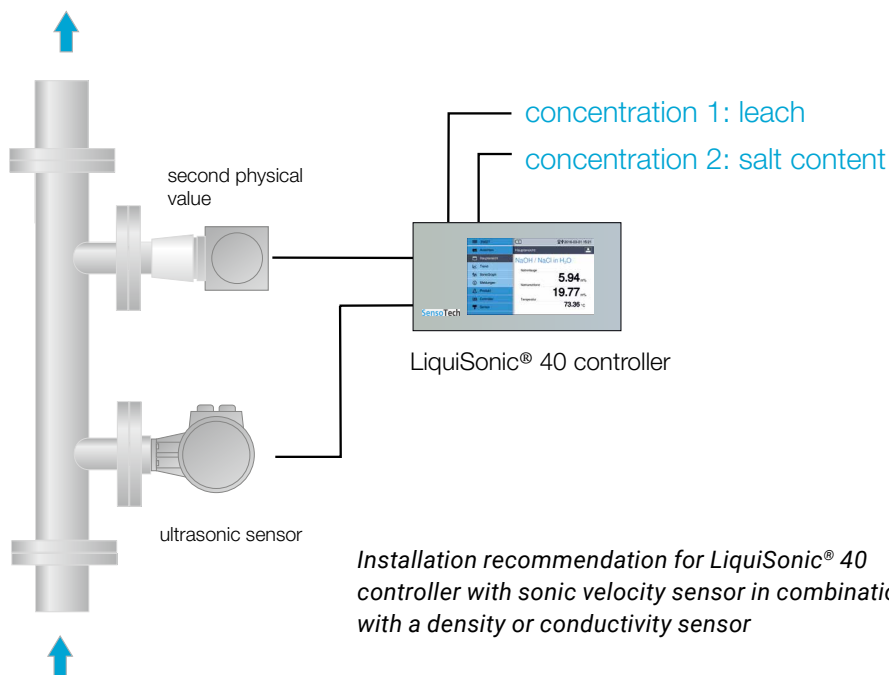

Analysis of 3-component mixtures with LiquiSonic[®]

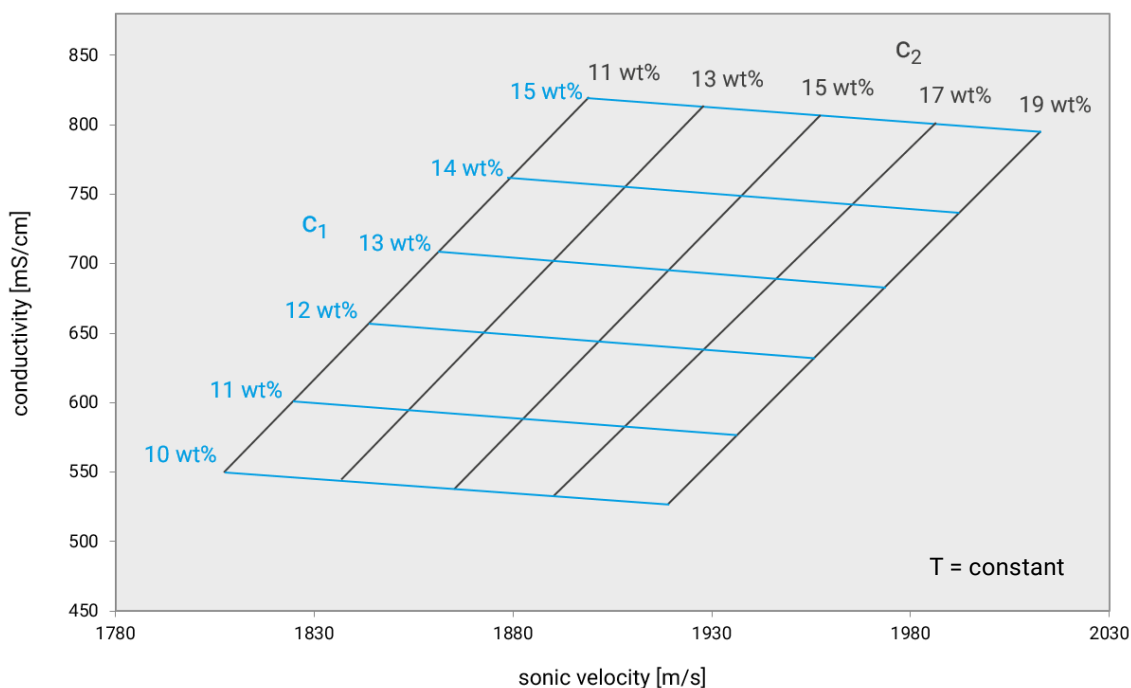

Methyl diethanolamine (MDEA)

Amine scrubbing is a chemical process for the separation of CO₂, H₂S and other acidic gases from natural gas. Here, a light alkaline watery solution of amines is used, which chemically absorbs the acidic gases in a reversible manner. Typically, MDEA exhibits greater selectivity for H₂S absorption, while AMDEA and DEA are more selective for CO₂ absorption.

The gas scrubbing aims at preparing the acidic natural gas for subsequent transport, according to the pipeline requirement. Otherwise, corrosive damage may be caused.

In the absorber, the natural gas is led through the washing liquid in the counter-flow. The cleaned natural gas exits at the upper end of the absorber. Due to its high selectivity regarding H₂S and CO₂, methyl diethanolamine (MDEA) is used as the absorbent.

After scrubbing, the MDEA contaminated with H₂S and CO₂ (rich amine) is transferred into the so-called stripper. In the stripping process, the scrubbing solution is heated, which causes the gases to be desorbed. Afterwards, the regenerated MDEA (lean amine) is cooled, filtered and re-supplied to absorption.

The LiquiSonic® measuring system allows for an exact analysis of the generated MDEA concentration as well as permanent data collection.

Due to the inline measuring, the amine scrubbing is monitored around the clock. In this way, reaction to fluctuating MDEA concentrations and an increase in the absorption efficiency are possible at any time.

Additionally, continuous measurement of the MDEA concentration eliminates the need for manual sampling and laboratory tests. In this way, material and labor costs can be saved and system safety can be increased.

LiquiSonic® ensures the cleanliness of the regenerated MDEA scrubbing solution for optimal absorption efficiency. Avoiding overdosing of the MDEA scrubbing liquid saves both costs and material.

The sensors are installed in the DN50 pipeline from the stripper to the absorber, after the amine cooler and the filter as well as in the MDEA tank.

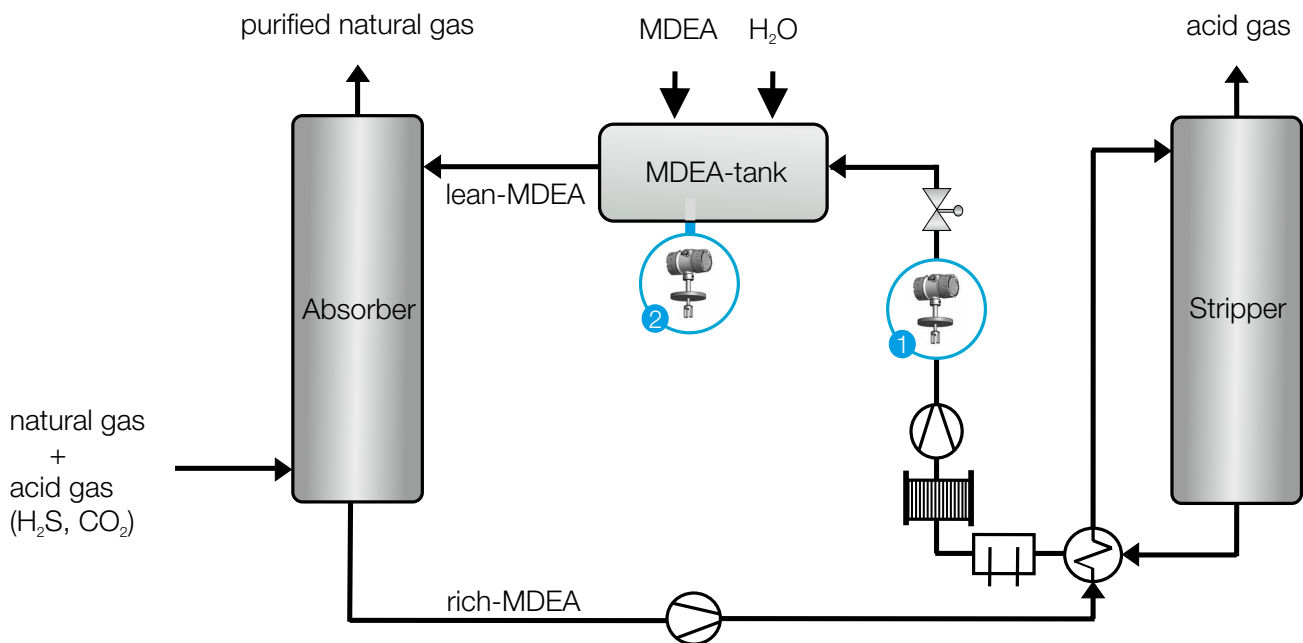

Measuring point	Installation	Measuring task
1	pipeline	real time control of the regenerated MDEA concentration
2	MDEA tank	monitoring the MDEA concentration directly in the MDEA tank

Installation of sonic velocity sensors in MDEA gas scrubbing

Benfield synthesis gas scrubber

Another procedure is the Benfield synthesis gas scrubber. It is, for example, used in ammonia synthesis or ethylene oxide production.

The Benfield process uses hot potassium carbonate solution (K_2CO_3) as an absorbent. The gas to be cleaned is absorbed by the K_2CO_3 solution in the absorber at high pressure (e.g. 2 MPa). This solution is enriched - in counter-flow - with CO_2 and is in a reaction partly converted to potassium hydrogen carbonate ($KHCO_3$).

The cleaned gas exits at the upper end of the absorber. The temperature in the absorption process usually ranges between 100 and 110 °C.

During desorption by means of steam and pressure loss, the absorbed CO_2 is released into the scrubbing liquid again. Afterwards, the regenerated K_2CO_3 flows back to the absorption circuit.

In the cleaning of gas flows however, the focus is on the avoidance of underdosing or overdosing of the scrubbing liquid. This is to minimize insufficient gas cleaning on the one hand, and excessive material use and related costs on the other hand. Continuous measurements, directly in the process, guarantee smooth concentration management.

Excessive $KHCO_3$ concentrations result in foam formation and reduced CO_2 absorption. Too little K_2CO_3 leads to

insufficient absorption. These concentration fluctuations of the scrubbing liquids are detected by the LiquiSonic® measuring system without time delay.

In this way, LiquiSonic® allows for automatic control of the K_2CO_3 solution in the range of maximum absorption, and/or maximum efficiency of the gas scrubber. Time-intensive laboratory measurements become unnecessary.

Avoiding overdosing and underdosing allows for the saving of material costs for absorber (K_2CO_3) and desorber (steam).

The LiquiSonic® immersion sensors can be easily installed directly into the pipeline. Typical places of installation include the pipelines (DN80) from the absorber to the desorber, and/or in its return.

The controller displays the measured concentration of the K_2CO_3 scrubbing liquid and the $KHCO_3$ salt and is connected to the process control room via fieldbus or analog outputs.

The LiquiSonic® controller is connected to an ultrasonic sensor and the measuring unit for the second physical parameter, preferably conductivity. In the main menu, the controller displays the concentration of the caustic soda and the salts. Immediate process feedback, avoiding delays associated with waiting for laboratory results.

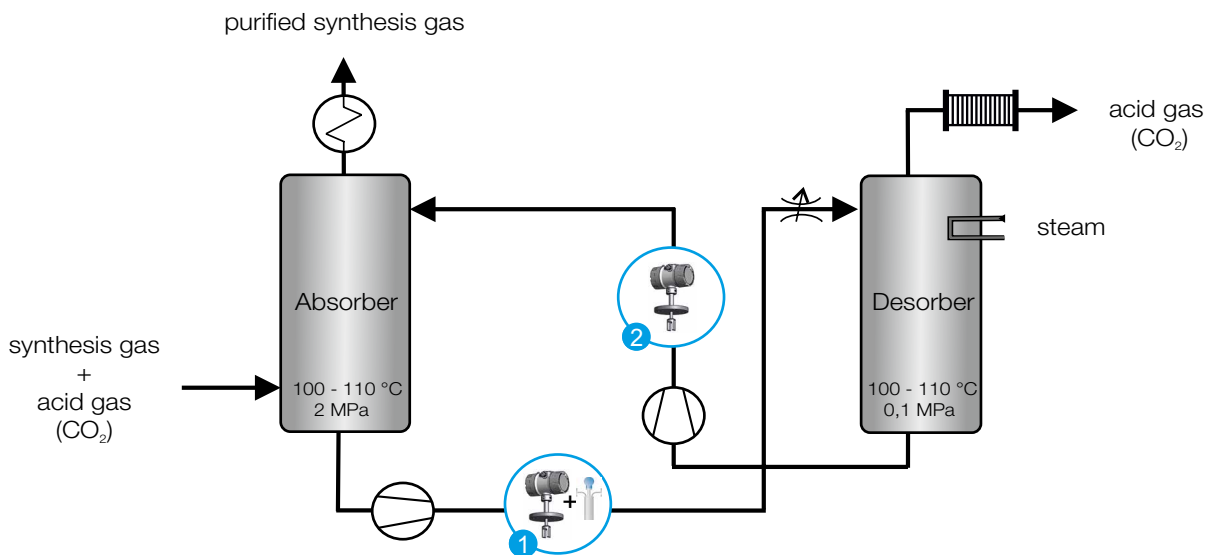

Measuring point	Installation	Measuring task
1	pipeline	monitoring of scrubbing liquid K_2CO_3 and the salt $KHCO_3$
2	pipeline	real time control of regenerated K_2CO_3 solution

Inline Benfield gas scrubber monitoring

Alkylation (HF, H₂SO₄)

The most important key processes in the petrochemical industry include alkylation systems. While the H₂SO₄ alkylation scores points with safety and environmental protection aspects, the HF alkylation typically shows an efficient acid recycling.

The system must ensure risk-free operation while optimizing economic and ecological aspects and maintaining consistent quality. With increasing requirements on the product quality of petrol and an increase in the octane rating, alkylation systems are more and more becoming the heart of refineries.

The robust LiquiSonic® measuring technology has set benchmarks in 3-component analysis for years. Using specialty materials, it effectively prevents corrosion, abrasion and drift even under difficult conditions.

Olefins (butene, propene) and the isoalkanes from raw oil resulting from Fluid Catalytic Cracking (FCC) constitute the starting materials. Together with HF and/or H₂SO₄ as catalyst, high-grade alkylates are formed.

Due to their high octane rating, few aromatic compounds and comparably environmentally friendly properties, they are perfectly suitable for petrol blending from both an economic and an ecologic point of view.

The most important requirement for the alkylation system is the error-free operation, also in case of fluctuating educt composition and secondary components.

To prevent an "acid runaway", a minimum ASO (acid soluble oil) content is desired. To prevent this economic extreme case, control of the acid, water and ASO quantity is extremely important.

Traditional sampling is potentially dangerous, time-consuming, and yields results only after several hours. In contrast, LiquiSonic® provides immediate inline analysis and data recording, enhancing system productivity.



Inline Benfield gas scrubber monitoring

Inline process control with the LiquiSonic® measuring system offers the following advantages:

- High system utilization due to maintenance-free function
- Consistent process stability and alkylate quality
- Corrosion protection due to inline determination of the current water content
- Avoidance of a fast acid consumption (acid runaway)
- Traceable monitoring with data recording
- Improved operational safety due to minimized sampling and laboratory analyses

Preventing overuse of MDEA scrubbing liquid not only reduces substance costs but also leads to significant savings. With a 1% overuse of MDEA, an inline measurement device can pay for itself within just a few months. Additionally, operators will benefit from reduced sampling and laboratory effort. Optimize your operations and cut expenses with accurate, real-time monitoring.



The LiquiSonic® immersion sensors can be easily installed directly into the pipeline and are ATEX-, IECEx- and FM-certified. Additionally, they are approved for high pressure levels, typically PN40 and ANSI 300 lbs

Possible installation locations include upstream and downstream of the acid separator, and at the alkylate outlet of the iso stripper.

Despite challenging and corrosive process conditions, the use of materials like Hastelloy C-276 has already proven successful in ensuring long-term system stability.

The LiquiSonic® controller is connected to the sonic velocity sensor and a density measuring device. In the main menu, the controller displays the concentration values of the acid and the ASOs.

Typical measuring task:

HF / H2SO4 concentration	80 - 95 wt%
Water concentration	0 - 10 wt%
ASO concentration	0 - 10 wt%
Temperature	10 - 30 °C / 50 - 90 °F
Druck	16-20 bar

Concentration values, as well as other parameters, such as temperature, sonic velocity and pressure, can be visualized at the LiquiSonic® controller in real-time.

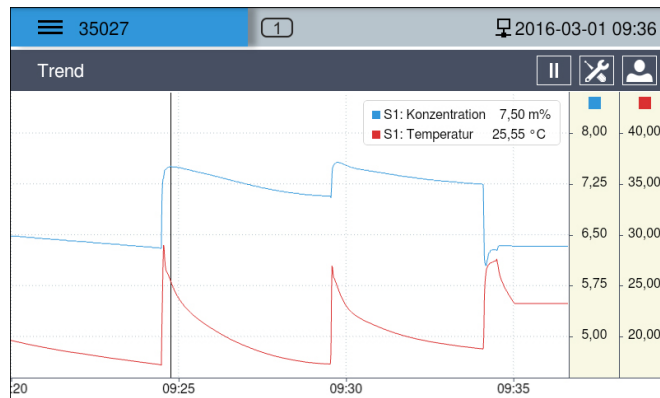

Trend view of the LiquiSonic® controller

LiquiSonic® concentration determination of sulfuric acid, water and butanol

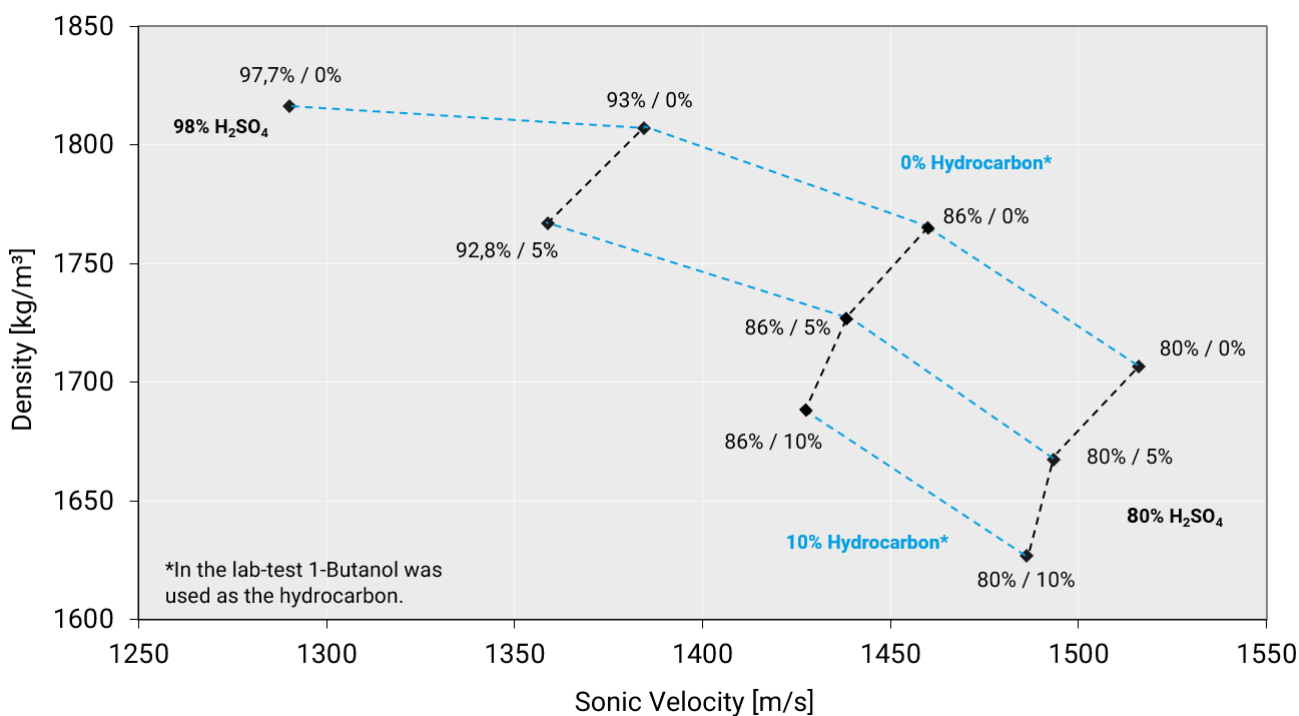

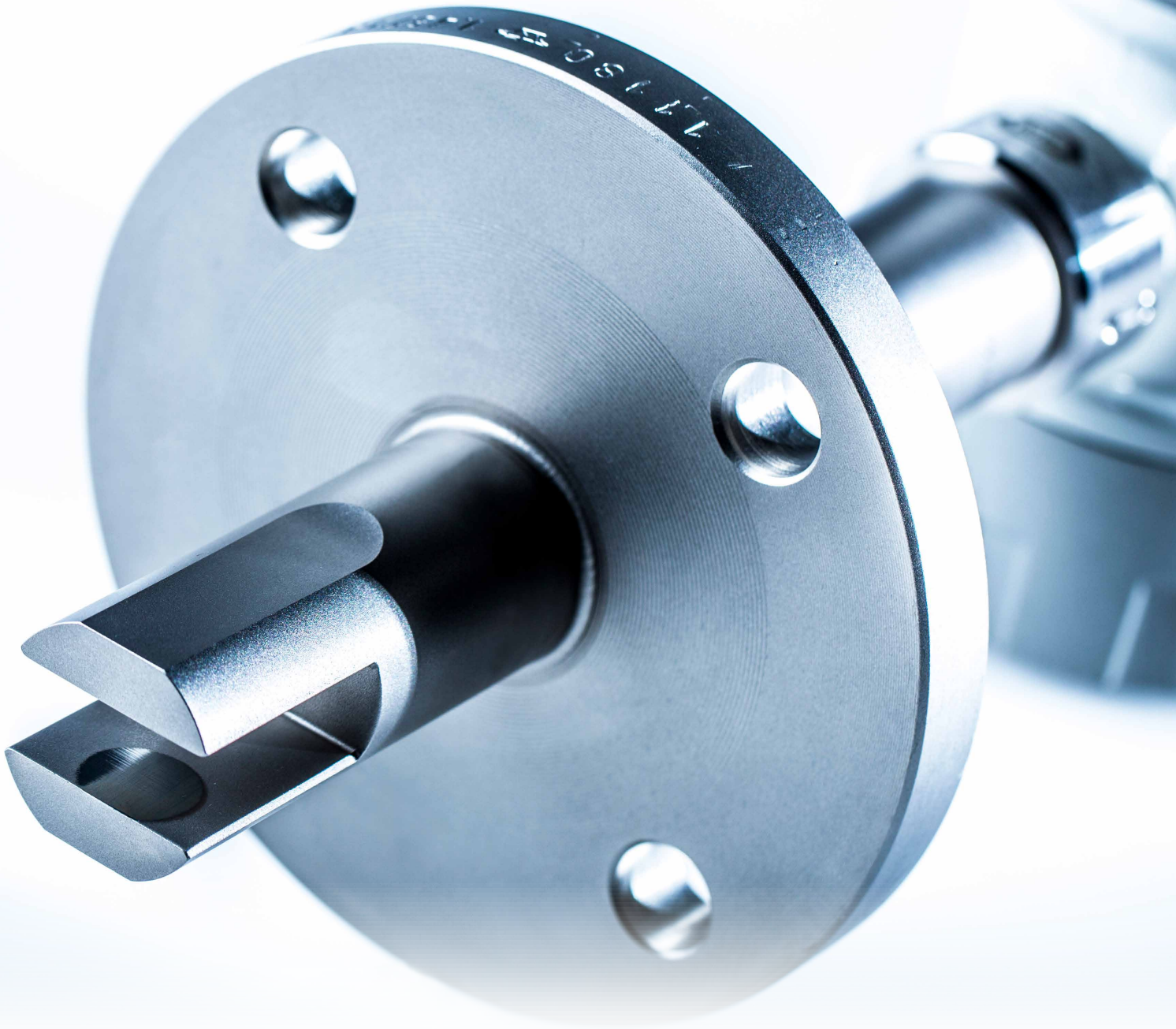

In liquids, we set the measure.



LiquiSonic® System

LiquiSonic® 20 and 30

The LiquiSonic® system consists of one or more sensors and one controller.

The ultrasonic sensor has the actual ultrasonic measuring path and the highly precise temperature detection.

The controller 30 is a highly efficient device which includes up to four sensors. They can be installed in different steps with a standard maximum distance of 1,000 m between controller and sensor. As option, higher distances are possible.

The controller 20 is a variant with a reduced scope of functions and only to one sensor connectable.

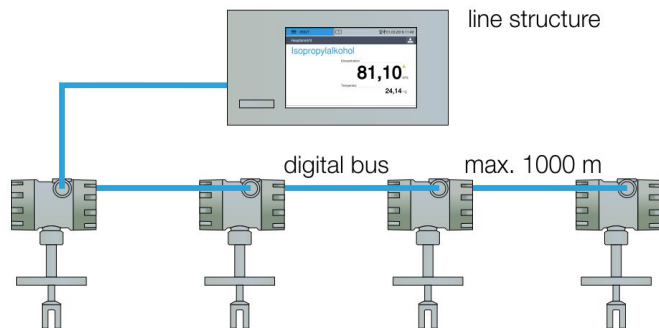

Controller with connection of maximum four sensors

Each sensor works autonomous and can be used in different applications. The liquid-wetted parts of the sensor are made of stainless steel DIN 1.4571 as standard. The rugged, completely enclosed design requires no gaskets or "window", making it totally maintenance-free.

Additional sensor features such as flow / stop or full / empty pipe monitoring greatly advance process control. The LiquiSonic® high-power technology stabilizes measuring results, even when facing gas-bubble accumulations or large-scale signal attenuation through the process flow.

The special sensor electronics are integrated in a closed die-cast housing with a protection degree of IP65. If necessary, the electronics housing can be mounted apart from the sensor.

For use in hazardous areas, the immersion sensor Ex 40-40 is approved by ATEX and IECEx certification (Ex d IIC T1 to T6 Ga/Gb, zone 0 / zone 1) and FM certification (Class I, Division 1, Groups A, B, C, DT1-T6).

The controller 30 processes and displays the measuring results. The operation via the high resolution touch screen is easy and intuitive. Secure network integration including web server allow operating the controller alternatively via a browser with a PC or tablet.

The process data is updated every second. The displayed value can be adjusted to internal reference values. If the measuring values exceed or fall below the threshold, the display shows an alarm message and a signal will be sent immediately.

The data can be transmitted in several defined analog or digital forms or through different fieldbus interfaces to communicate with process control systems or computers.

The controller features an integrated data logger which can store up to 2 GB of process information with up to 32 (optional 99) data sets for different process liquids. For processing on the PC, the data can be transferred via network or USB port. In addition, the controller enables easily creating process reports for documentation purposes.

The event log records states and configurations such as manual product switches, alarm messages or system states.



Immersion sensor Ex 40-40

LiquiSonic® 40

The LiquiSonic® 40 analyzer enables the determination of concentration in 3-component liquids. For example, in neutralization processes it is possible to determine separately the concentration of the scrubbing solution and the salt.

The measuring principle is based on the fact that concentration changes of individual components of a liquid affect physical quantities like sonic velocity, conductivity or density. This characteristic is stored as calculation mode in the evaluation unit (controller) to convert the physical variables in concentration values.

With the parallel detection of two physical variables (sonic velocity and conductivity), it is possible to determine two concentrations at the same time.

The measuring values are available for the user or process control system over analog outputs as well as fieldbus.

For the application in aggressive liquids, the standard LiquiSonic® 40 is equipped with a Halar (also known as E-CTFE) coated flange sensor and a PFA or PEEK coated conductivity sensor, which are chemically resistant to a number of substances.

The flange sensor has a highly efficient ultrasonic ceramic to ensure the measurement even at high portion of gas in the liquid. For the application in hazardous areas, the flange sensor has an ATEX and IECEx approval (II 1/2 G / Ex d IIB T1 to T6 Ga/Gb) .



LiquiSonic® controller and Halar coated flange sensor

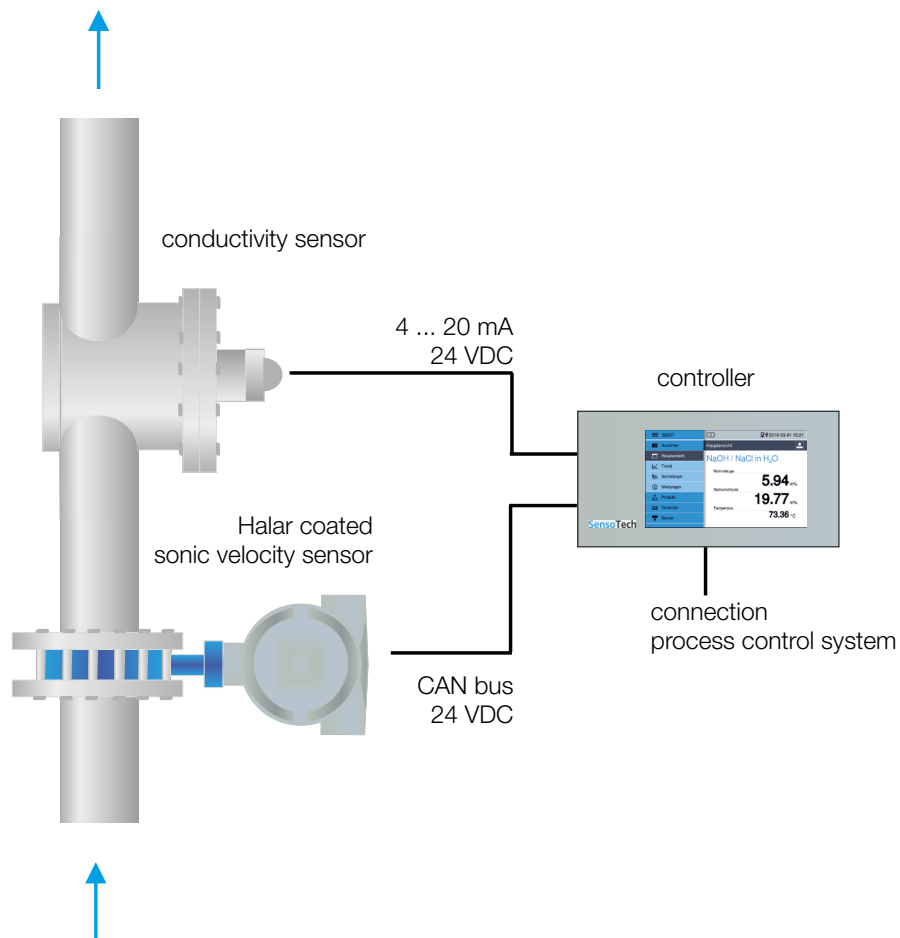

Installation recommendation for the LiquiSonic® 40 controller in combination with ultrasonic sensor and conductivity sensor

Accessories

There are several possibilities to install the LiquiSonic® analyzer appropriately and to facilitate the integration into the process control system. The following products have proved to be useful.



Controller rack mounting 19" 4 HE

Controller rack mounting

The controller is designed for rack-mounted systems. It is alternatively available with a 19" housing 4 HU. In order to be able to mount the controller into the field, two variants of field housings made of plastic or stainless steel can be delivered, which meet on-site conditions in an optimal way.

- material: anodized aluminum
- dimensions: 482.9 (19") x 177 (4 HU) mm
- application: rack-mounted system

Fieldbus

The fieldbus option provides the possibility to integrate the controller in a PCS or to automate the process flow via PLC. Beside the transfer of measuring values like concentration and temperature it is also possible to exchange parameters and control data (for example product switch).

The controller supports different fieldbus systems and follows the standards recommended by the respective standards organizations. Common variants are Modbus, Profinet, Profibus DP and CAN Bus.

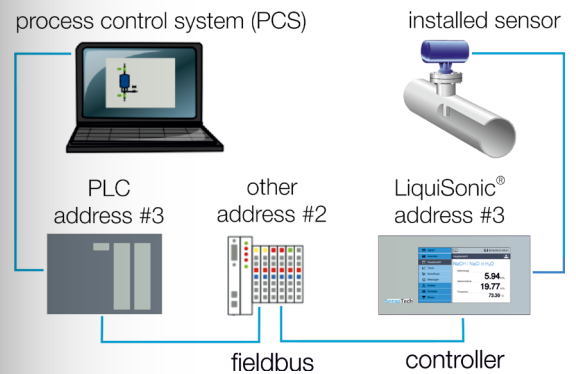

Connection interfaces



Controller stainless steel housing

Controller stainless steel housing

The controller is designed for the installation in control panels. In order to install the controller in the field, a stainless steel housing is available.

- material: stainless steel DIN 1.4301 (AISI 304)
- protection degree: IP66 (NEMA 4X)
- dimensions: 430 x 300 x 230 mm
- window: VSG with 6 mm thickness
- application: in areas with highly hygienic requirements like pharmaceutical and food industry, e.g. breweries



Network Integration

The LiquiSonic® controller has an Ethernet interface, that makes the integration into the corporate network possible. After entering the user name and password, the access to the stored logs is possible.

Integrating the controller into the network enables remote control, view of status information, transfer of product data sets or calibration of products.

The Network integration includes

- web server (HTTP),
- command line (TELNET),
- file transfer (FTP),
- time synchronisation (NTP),
- e-mail notification (SMTP).



Quality and Support

Enthusiasm for technical progress is the driving force behind our company as we seek to shape the market of tomorrow. As our customer you are at the center of all our efforts and we are committed to serving you with maximum efficiency.

We work closely with you to develop innovative solutions for your measurement challenges and individual system requirements. The growing complexity of application-specific requirements means it is essential to have an understanding of the relationships and interactions involved.

Creative research is another pillar of our company. The specialists in our research and development team provide valuable new ways to optimize product attributes, such as testing new types of sensor designs and materials or the sophisticated functionality of electronics, hardware and software components.

Our SensoTech quality management also only accepts the best production performance. We have been certified according to ISO 9001 since 1995. All device components pass various tests in different stages of production. The systems have all gone through an internal burn-in procedure. Our maxim: maximum functionality, resilience and safety.

This is only possible due to our employee's efforts and quality awareness. Their expert knowledge and motivation form the basis of our success. Together we strive to reach a level of excellence that is second to none, with passion and conviction in our work.

Customer care is very important to us and is based on partnerships and trust built up over time.

As our systems are maintenance free, we can concentrate on providing a good service to you and support you with professional advice, in-house installation and customer training.

Within the concept stage we analyze the conditions of your situation on site and carry out test measurements where required. Our measuring systems are able to achieve high levels of precision and reliability even under the most difficult

conditions. We remain at your service even after installation and can quickly respond to any queries thanks to remote access options adapted to your needs.

In the course of our international collaboration we have built up a globally networked team for our customers in order to provide advice and support in different countries.

We value effective knowledge and qualification management. Our numerous international representatives in the important geographical markets of the world are able to refer to the expert knowledge within the company and constantly update their own knowledge by taking part in application and practice-oriented advanced training programs.

Customer proximity around the globe: an important element of our success worldwide, along with our broad industry experience.



In liquids, we set the measure.
With innovative sensor technology.
Tough, accurate, user-friendly.

SensoTech

SensoTech is a provider of systems for the analysis and optimization of process liquids. Since our establishment in 1990, we have developed into a leading supplier of process analyzers for the inline measurement of liquid concentration and density. Our analytical systems set benchmarks that are used globally.

Manufactured in Germany, the main principle of our innovative systems is to measure ultrasonic velocity in continuous processes. We have perfected this method into an extremely precise and remarkably user-friendly sensor technology. Beyond the measurement of concentration and density, typical applications include phase interface detection or the monitoring of complex reactions such as polymerization and crystallization.

Our LiquiSonic® measuring and analysis systems ensure optimal product quality and maximum plant safety. Thanks to their enhancing of efficient use of resources they also help to reduce costs and are deployed in a wide variety of industries such as chemical and pharmaceutical, steel, food technology, machinery and plant engineering, car manufacturing and more.

It is our goal to ensure that you maximize the potential of your manufacturing facilities at all times. SensoTech systems provide highly accurate and repeatable measuring results even under difficult process conditions. Inline analysis eliminates safety-critical manual sampling, offering real-time input to your automated system. Multi-parameter adjustment with high-performance configuration tools helps you react quickly and easily to process fluctuations.

We provide excellent and proven technology to help improve your production processes, and we take a sophisticated and often novel approach to finding solutions. In your industry, for your applications – no matter how specific the requirements are. When it comes to process analysis, we set the standards.

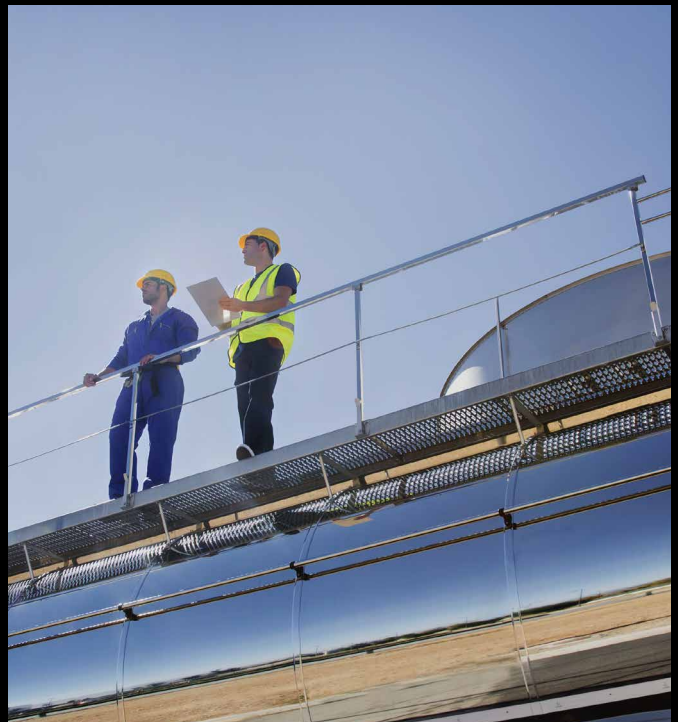
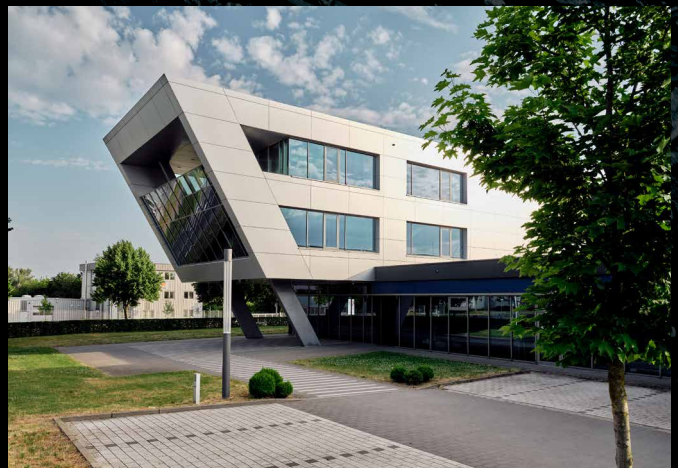



SensoTech GmbH
Steinfeldstraße 1
39179 Magdeburg-Barleben
Deutschland
+49 39203 514 100
info@sensotech.com
www.sensotech.com

SensoTech Inc.
69 Montgomery Street, Unit 13218
Jersey City, NJ 07303
USA
+1 973 832 4575
sales-usa@sensotech.com
www.sensotech.com

SensoTech (Shanghai) Co., Ltd.
Room 609, Bldg.1, No.778, Jinji Road.
Pilot Free Trade Zone, 201206 Shanghai
China
+86 21 6485 5861
sales-china@sensotech.com
www.sensotechchina.com



LSM140_01_04